

ITEM # FDBSTAND FOLDABLE BIKE STAND

ASSEMBLY INSTRUCTIONS

- A) Wheel Brace
- B) Main Arm
- C) Arm Lock
- D) Spring
- E) Wheel Channel
- F) Connecting Brackets
- G) End Caps

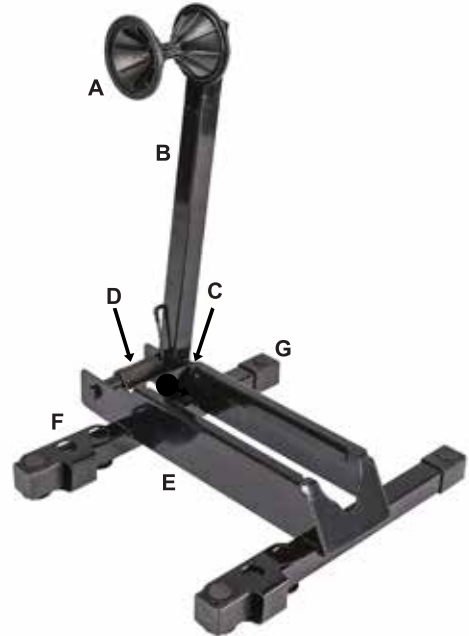

- 1) Grab the Main Arm (B) and pull it forward.
- 2) When the spring tension (D) LOCKS, the unit is ready to use.
- 3) To fold for storage, PRESS the (C) Arm Lock and fold the Main Arm.
- 4) Use the (F) Connecting Brackets to attach an additional Bike Stand.



▲ WARNING

DO NOT OVERLOAD! Max Weight Capacity is 44 lbs.

IF THERE IS ANY QUESTION ABOUT A CONDITION BEING SAFE OR UNSAFE, DO NOT USE THIS PRODUCT!

If you experience a problem, have questions or need parts for this product, call Customer Service at 1-636-532-9888, Monday - Friday, 8 AM - 4 PM Central Time. A copy of the sales receipt is required. KEEP THIS MANUAL, SALES RECEIPT & APPLICABLE WARRANTY FOR FUTURE REFERENCE.

▲ WARNING

Do not climb, step or support any item other than the intended product use. This is not a toy - keep out of reach of children. Serious injury can occur if this item is misused.

ITEM # FDBSTAND FOLDABLE BIKE STAND

ASSEMBLY INSTRUCTIONS

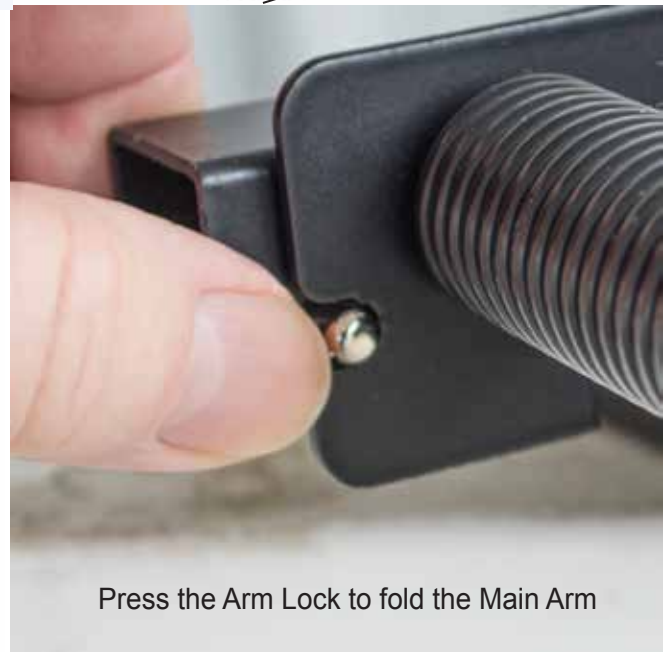
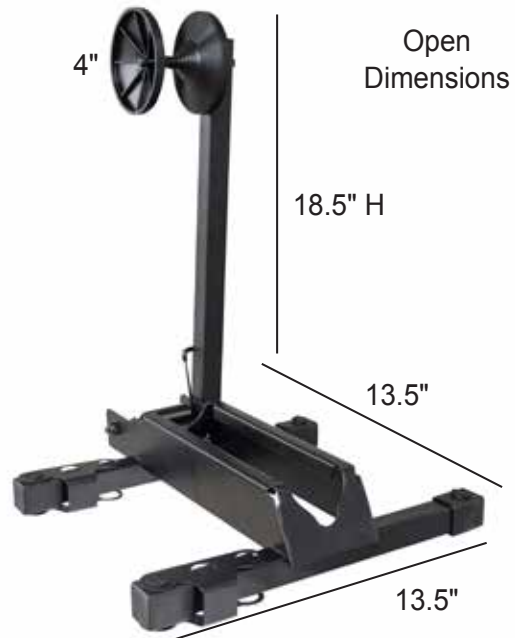

Connect Two Units Together For Multiple Bike Storage

Spacing of 14" - 15" Between Stands When Connected



Wheel Brace is already attached, but the 3" width can be adjusted 1/4" (using the two included wrenches) to allow for wider tires.